

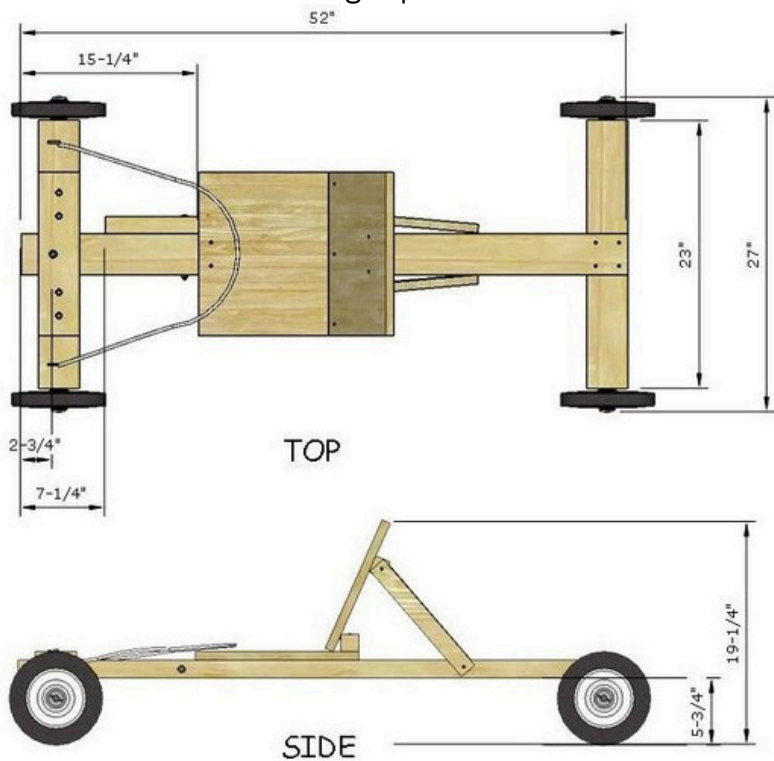

# Soap Box Derby Kit Assembly Instructions 2026



These instructions will guide you through building a simple, inexpensive soapbox derby car. Most families can complete this build for approximately \$80–\$100. The instructions are written for adults assisting children and assume an average level of building experience.



## Exploded View Reference

Refer to these drawings if you have any questions or need more clarification. We have done our best to show all the components and where they should be assembled.

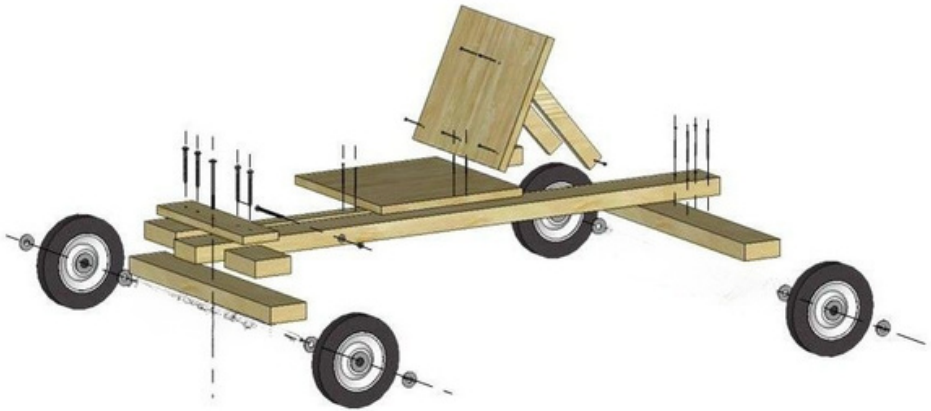

Note: If anything appears to be missing or slightly the wrong size, most local hardware stores in the area have been briefed on this kit and should be able to help.

## **Safety First**

Children should be supervised by an adult throughout the build.

Before you begin:

- Wear safety glasses whenever you are drilling.
- Wear work gloves to protect your hands.
- Follow all safety guidelines in the owner's manual for any power tools you use.

Feel free to customize and personalize your car once the basic build is complete.

## Tools Required:

The following tools will be needed to construct this kit.

- Safety Glasses
- Work Gloves
- Tape Measure
- Pencil
- Drill
- Drill & Screw Bits
- Socket Set
- Adjustable Wrench
- Pliers

## Notes:

## Components:

The following components are included in the kit. You will have extra hardware left after you complete the kit

### Wood Parts

2 - 2"x4" @ 23"	1 - 3/4" Plywood @ 12"x14"
2 - 2"x4" @ 5"	1 - 2"x2" @ 5"
1 - 2"x4" @ 52"	1 - 2"x2" @ 14"
1 - 1"x4" @ 14"	1 - 2"x2" @ 21"
1 - 3/4" Plywood @ 14"x14"	2 - 1"x2" @ 12"

### Hardware

4 - 1/4" x 3-1/2" Lag Bolts	20 - 1/2" Copper Pipe Holders
4 - 1/4" Fender Washers	40 - 1-1/4" Screws
1 - 5/16" x 5" Carriage Bolt	8 - 1/2" Fender Washers
1 - 5/16" x 5-1/2" Carriage Bolt	4 - 1/8" x 1-1/4" Cotter Pins
3 - 5/16" Fender Washers	2 - 1/2" x 28" Steel Axles
2 - 5/16" Stop Nuts	4 - Wheels
4 - 2-1/2" Screws	2 - #4 2-5/16" - 5/8" Eyebolts
3 - 2" Screws	1 - Section of Rope
15 - 1-5/8" Screws	

# Hardware Reference Sheet

2 - 5/16" Stop Nuts



4 - 1/4" Fender Washers



3 - 5/16" Fender Washers



8 - 1/2" Fender Washers



2 - #4 2-5/16" -  
5/8" Eyebolts

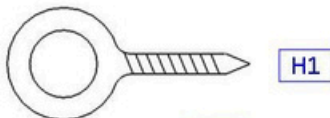

4 - 1/8" x 1-1/4"  
Cotter Pins



4 - 2-1/2" Screws

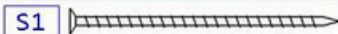

3 - 2" Screws

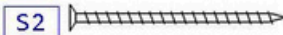

15 - 1-5/8" Screws

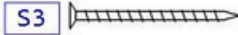

40 - 1-1/4" Screws



1 - 5/16" x 5-1/2"  
Carriage Bolt

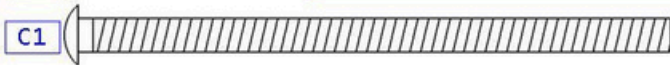

1 - 5/16" x 5"  
Carriage Bolt

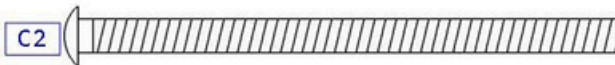

4 - 1/4" x 3-1/2"  
Lag Bolts

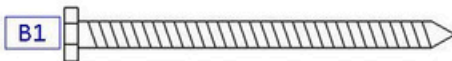

## Note:

The screws are printed at actual size. You can lay hardware on the sheet to confirm correct size.

## Step #1 Front Steering Column

In this step, you will assemble the front steering column using three pieces of wood that should already be labeled and taped together in your kit.

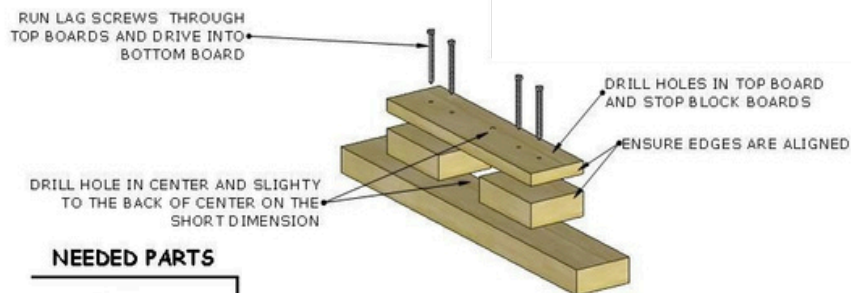

### NEEDED PARTS

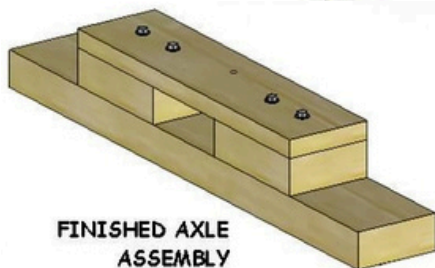
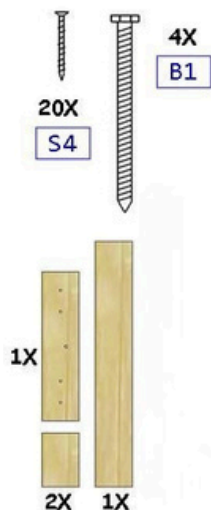

Stack the boards so that all edges are aligned, then run the lag screws down through the top boards and into the bottom board. Before fully tightening, drill a hole in the center of the assembly – positioned slightly toward the back of center on the short dimension – for the pivot bolt that will connect the steering column to the frame in the next step.

## Step #2 Attaching the frame board

In this step, you will attach the 2"x4"x52" frame board to the front steering column you assembled in Step 1.

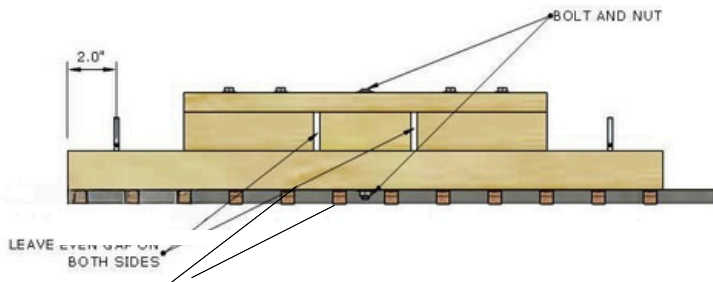

### NEEDED PARTS

2" x 4" x 52" Frame Board

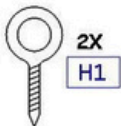

2X

H1



1X

W2

C2



1X

W2



1X

N1

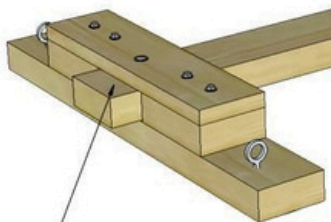

LEAVE APPROX 1.5"  
TO 2.0" EXTENDED  
PAST THE AXLE

Slide the frame board into the axle assembly and position it where you want it, leaving 1.5" to 2.0" extending past the axle on the front end. Make sure there is an even gap on both sides of the steering column. Clamp the board in place, then drill a hole straight down through the frame board and into the steering column.

Secure the frame board to the steering column using the carriage bolt, washer, and stop nut. Install the two eyebolts through the steering column — these will be used for the steering rope later.

Note: It is easiest to drill the pivot hole while the board is clamped in position. Take your time aligning before you drill.

### Step #3 Attaching the Rear Wheel Base

In this step, you will attach the rear wheel base to the frame board, completing the basic chassis

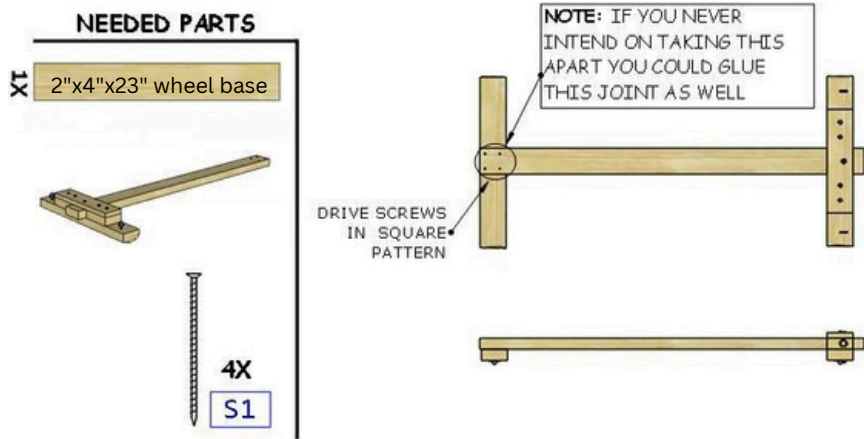

Center the rear wheel base across the back end of the frame board at a 90-degree angle, just as the front steering column is positioned on the front. Drive the four screws in a square pattern to secure the joint firmly.

Note: If you do not plan to disassemble this car after the event, you can also apply wood glue to this joint for added strength before driving the screws.

## Step #4

In this step, you will build and attach the seat. Follow the sub-steps below in order – the sequence matters.

### \*\* FOLLOW STEPS IN ORDER \*\*

- 1 Place the seat bottom on the frame board without attaching it yet. Have the driver sit on it with their feet resting on the front steering column to find the most comfortable position. Mark that location on the frame board, then screw the seat bottom down.
- 2 Stand the seat back upright and screw it to the 2x2 block on the seat bottom at whatever recline angle is comfortable for the driver. Once the angle is set, tighten the screws on the brace arms fully.
- 3
- 4
- 5 Rotate the seat back assembly until it is aligned with the frame board, then drive screws through the seat back into the frame to lock it in place. Finish by fully tightening all remaining screws.

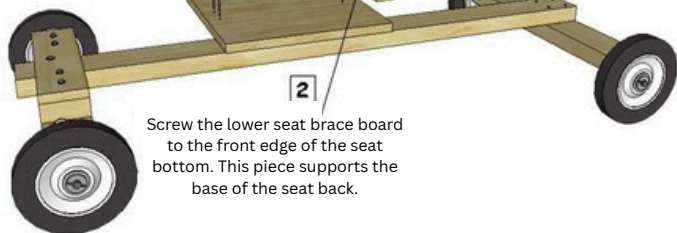

Screw the lower seat brace board to the front edge of the seat bottom. This piece supports the base of the seat back.

### NEEDED PARTS

3X S4

13X S3

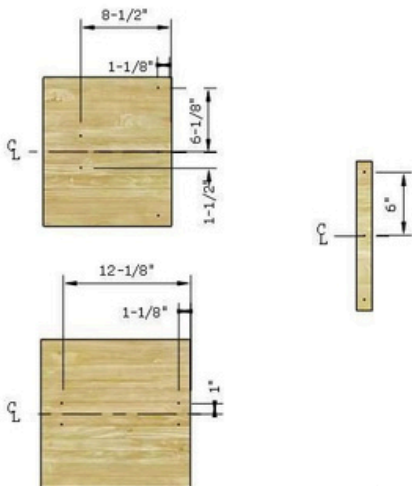
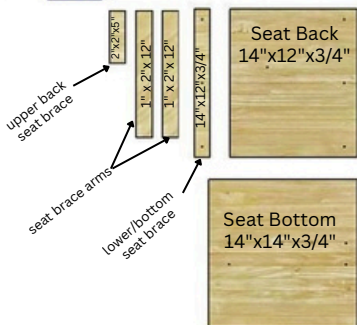

## Step #5 Attaching the Brake

In this step, you will attach the brake board and set up the rope pull system that the driver will use to slow the car. Drill a 5/16-inch hole through the frame board, positioning it slightly in front of the seat for easy driver reach. Locate the piece of wood labeled "brake." Attach it to the frame board using the carriage bolt, placing one washer between the brake and the frame board, and a second washer between the frame board and the stop nut. The brake should pivot freely – do not overtighten.

Note: Drill the hole slightly off-center on the brake board itself so the pivot point sits just in front of the driver's seat. Have the driver sit in the seat to confirm the brake is within comfortable reach before finalizing placement.

### NEEDED PARTS

2" x 2" x 21" brake  
1X



1X

C1



2X

W2



1X

N1



FOR THE BRAKE, YOU WANT TO HAVE THE PIVOT SLIGHTLY IN FRONT OF THE SEAT FOR EASE OF USE. DRILL THE HOLE SLIGHTLY OFF CENTER ON THE BRAKE BOARD

THIS IS APPROXIMATELY WHERE THE ROPE SHOULD SIT ON THE SEAT.

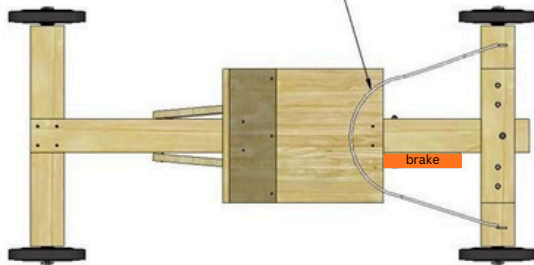

### Attaching the Rope

Thread the rope through the eyebolts on the steering column and tie it so the driver can pull it comfortably while seated. Have the driver sit in the seat to find the correct rope length before tying off. When the driver pulls the rope, it should press the brake board down against the ground to slow the car.

## Step #6 Creating the Wheel Axle

In this step, you will be creating the wheel axle. Inside your hardware bag, locate the smaller bag labeled "wheels." It contains the U-brackets, bolts, washers, screws, and locking nuts you will need for this step. Begin by assembling the wheel component. Slide the bolt through the center of the wheel from the outside, then thread the nut onto the bolt – this nut acts as a spacer that will keep the wheel from rubbing against the wood. Slide the washer onto the bolt after the nut, so that the end of the crossmember will rest firmly against the washer when the wheel is pressed into place.

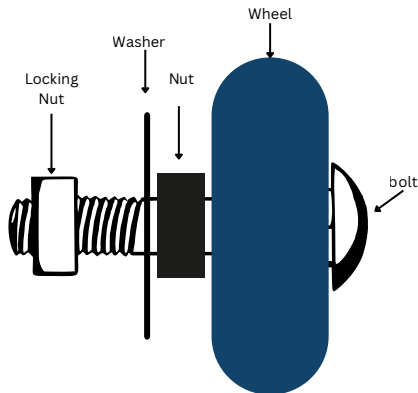

## Step #7 Attaching the Wheels

In this step, you will attach the wheels to the axle crossmembers of the frame. Hold the assembled wheel component against the end of the axle crossmember so the washer sits flush against the wood. Thread the locking nut onto the exposed end of the bolt so that it sits between the wood and the U-bracket. Hold the U-bracket in place around the bolt and flat against the side of the wood, trapping the locking nut in position. Using the bracket as a guide, mark the screw hole locations on the wood with a pencil. Pre-drill a pilot hole at each mark to prevent the wood from splitting. Drive the screws in firmly until the bracket sits flat and tight against the wood. The wheel should spin freely with no side-to-side wobble. Repeat this process for all four wheels.

Note: The diagram above shows one U-bracket per wheel for clarity. Your hardware bag includes two U-brackets for each wheel. We recommend placing one bracket close to the locking nut and a second bracket near the end of the crossmember. The closer the second bracket is to the end of the wood, the more secure your wheel will be.

